

Dynamic Patterns

The Self-Organization of Brain and Behavior

J. A. Scott Kelso

A Bradford Book
The MIT Press
Cambridge, Massachusetts
London, England

© 1995 Massachusetts Institute of Technology

All rights reserved. No part of this book may be reproduced in any form by any electronic or mechanical means (including photocopying, recording, or information storage and retrieval) without permission in writing from the publisher.

This book was set in Palatino by Asco Trade Typesetting Ltd., Hong Kong and was printed and bound in the United States of America.

Library of Congress Cataloging-in-Publication Data

Kelso, J. A. Scott.

Dynamic Patterns : the self-organization of brain and behavior / J. A. Scott Kelso.

p. cm.

"A Bradford book."

Includes bibliographical references and index.

ISBN 978-0-262-11200-0 (hardcover), 978-0-262-61131-2 (paperback)

1. Neuropsychology. 2. Self-organizing systems. I. Title.

QP360.K454 1995

612.8—dc20

94-32105

CIP

10 9 8 7 6

To Betty, Kate, and Alex for their love and a little tale

self-organization lie behind all structure or pattern formation, and, later, that the brain itself is an active, dynamic, self-organizing system. This paradigm of understanding how cooperation among the parts of a system generates patterns opens up an entirely new (or at least different) research program for the behavioral and brain sciences.

What do I mean by understanding? I obviously don't mean some privileged level of analysis where the fundamental units of brain function reside. Or that some molecule constitutes an elementary unit of cognition. Or even, as some would have it, that behavior itself is composed of some fundamental unit, like a reflex or a program, that must be studied and further decomposed, perhaps, into some even more elementary constituents. My point is that we will not be bound to the properties of matter itself, or draw our laws strictly from them. In the theory that I will propose no single level of analysis has priority over any other. The psychologist studying overt behavior doesn't have to look over her shoulder at the neuroscientist studying the insides of the nervous system, or the neuroscientist at the chemist, or the chemist at the physicist, and so on.

Understanding will be sought in terms of essential variables that characterize patterns of behavior regardless of what elements are involved in producing the patterns or at what level these patterns are studied or observed. To quote Napoleon Bonaparte, "They may say what they like, everything is organized matter." I will try to avoid dualities such as top-down versus bottom-up and macro versus micro because I think they can be misleading. What is macro at one level, after all, can be micro for another. Molecules, for example, are too macroscopic for a particle physicist to study, and too microscopic for the typical physiologist. Understanding will come by deploying a particular *strategy* to investigate complex systems such as human beings, and the reductionism will be to *principles* (or what I call *generic mechanisms*), that apply across different levels of investigation.

This emphasis is on self-organized pattern formation precisely because we will see that the same principles are at work even though the stuff that is producing the patterns may be very different indeed. Emergent properties are a significant feature of all complex systems in nature, and our goal will be to identify some of the key processes involved in emergence. Details will be shown to be important for understanding how cooperation among the components of a system creates new patterns in a self-organized fashion. Once we accept this more abstract, pattern level of analysis, we start to see common underlying processes and principles of self-organization that transcend animate and inanimate nature.³ And we start to see how enormously complex behavior can arise from a few simple (but nonlinear) rules. At first blush, all this must appear rather strange. You mean, the reader asks, that some deep relationship might exist between, say, the changing weather pattern and me changing my mind? Sounds totally crazy! But I would say the real question is not whether it's crazy at all, but whether it's crazy (or creative) enough.

WHAT IS A PATTERN?

Pattern (*pat' ern*), n. 1. A natural or chance marking, configuration or design; patterns of frost on the window. 2. A combination of qualities, acts, tendencies etc. forming a consistent or characteristic arrangement: the behavior patterns of teenagers.⁴

Everybody knows the world is made up of processes from which patterns emerge, but we seldom give pause to what this means. Maybe it's enough to know a pattern when we see it. Some patterns appeal to us more than others: the beautiful snow crystal, a butterfly's wings, the hive of a honeybee. Pattern is at the heart of great science and art: praise be the one who discovers or creates some underlying unity or truth in the world that surrounds us. Human beings are exceptional at detecting patterns even when the patterns are embedded in a field of randomness and disorder, as we will see later (chapter 7). I often tell my students that the genius of Galileo was that he could abstract the relation (form a pattern in his mind) between a ball rolling down an inclined plane and the motions of the planets. Even the greatest intellectual achievements of human beings have to do with patterns.

When we talk about patterns, we step back from things themselves and concentrate on the *relations* among things.⁵ My main concern will be with the behavioral patterns or modes of organized behavior produced by living things on different levels of description. Although I won't try to explain the behavior patterns of teenagers (at least just yet), I will extricate elementary concepts and principles that apply to *all* of pattern formation, relatively independent of who or what the component elements are. And since patterns continually form and change, I will introduce some of the main concepts and tools that scientists use to describe their evolution.

KINDS OF PATTERNS

Most of an organism most of the time is developing from one pattern to another not from homogeneity into a pattern.

—A. M. Turing

The brilliant Englishman Alan Turing, whose name is often associated with the development of the digital computer (and breaking the secret code used by the Nazis in WWII) had a lesser-known but profound interest in how patterns form in nature.⁶ I put his words up front because they capture the essence of the kinds of patterns on which I wish to concentrate. First, Turing's reference to organisms places an emphasis on the patterns produced in animate nature (see box). It will turn out, however, that the basic pattern-forming principles apply to both animate and inanimate systems.

The caveat, of course, is that an inanimate system, say, a fluid or a chemical reaction, must be *far from thermal equilibrium*. Enormously interesting and

THE TWO SIDES OF TURING

I am reminded of a famous scientist who was always arguing that the brain is not a Turing machine. When I noted during one of his lectures that there was another Turing, he was quite adamant: "No, No, there's only one Turing. You know, the Turing of the Turing machine!" After writing some equations on the blackboard describing chemical patterns, he paused and stared at me. "Ah, I see what you mean," he said. The equations that he had written on the board were the very ones Turing used to describe "the chemical basis of morphogenesis" in a remote paper published in 1952. My "two Turing's" refer to the genius who, on the one hand, made significant contributions to programmable computers, and on the other, showed how patterns in nature can emerge without any programmer at all. Only quite recently have the patterns predicted by Turing been observed experimentally, and Turing's theory still figures quite prominently in developmental biology.⁷

important structures studied by physicists, such as ferromagnetism, or superconductivity in which matter changes its microscopic structure as the temperature is lowered, are not our primary interest. And even though we might find ice crystals beautiful to look at, they are too orderly and rigid states of matter to be of relevance here. Systems in thermodynamic equilibrium are as dead as anything can be.

Only systems that are pumped or energized from the outside (or, like living systems who happen to possess metabolic machinery, from the inside and the outside) are capable of producing the kinds of patterns and structures that interest us. These are called open, nonequilibrium systems: open in the sense that they can interact with their environment, exchanging energy, matter or information with their surrounds; and nonequilibrium, in the sense that without such sources they cannot maintain their structure or function.

In the last twenty years or so, tremendous progress has been made in understanding how patterns form in open, nonequilibrium systems, especially by my friend and colleague Hermann Haken.⁸ Thanks to him and others,⁹ ordinary matter, under certain conditions, has been shown to exhibit lifelike properties. I will draw especially on Haken's work because it provides the theoretical foundation for some of the later developments in neuroscience and psychology that are the primary focus of this book. My aim is to show how principles of pattern formation may be adapted for and tailored to special features of living things, how they perceive and act, learn and remember.

Another reason why Turing's quotation captures what we are after is that he emphasizes that even primitive organisms are not structureless things composed of homogeneously distributed elements. They always have some kind of intrinsic organization. Although this seems rather obvious, it will turn out that profound consequences result from recognizing that organisms are not *tabulae rasae*. Many scientists who study learning, even at the cellular level, fail to appreciate this point, which I will develop in chapter 6. Parenthetically,

the important role of intrinsic organizational processes resonates strongly with early Gestalt theory in psychology, which sought natural principles of autonomous order formation in perception and brain function (see chapter 7). As we will see, entirely new concepts of self-organizing dynamical systems are necessary to replace the older physical ideas available to the Gestaltists.

Relatedly, *becoming* is a process of change, and this change often takes the form of an order-order transition from one pattern to another. The famous physicist Erwin Schrödinger, who earned the Nobel Prize for his contributions to quantum mechanics (the Schrödinger wave equation), also stressed the principle of order-order transitions for understanding life.¹⁰ He considered the physicists' emphasis on disorder-order transitions as completely irrelevant to the emergence of life processes. In physics, different aggregate states of matter—solid, liquid, gaseous—are called *phases*, and the transitions between them are called *phase transitions*. When vapor changes to liquid and eventually to ice, this is an example of progressive change from disorder to order. We see immediately that life processes have nothing to do with this kind of phase transition, and that entirely different principles having to do with nonequilibrium phase transitions are required.

Finally, Turing's reference to developing and evolving patterns stresses the dynamic aspect of pattern formation and even the continuously changing nature of the patterns themselves. For this reason, the principles we seek are for dynamic patterns, not static ones. All structures in animate nature are actually dynamic. We tend to think of some of them as static, but this is not really the case. Here I will adopt the view that structures and behaviors are both dynamic patterns separated only by the time scales on which they live.

PRINCIPLES OF DYNAMIC PATTERN FORMATION

Any principle of pattern formation has to handle two problems. The first is how a given pattern is constructed from a very large number of material components. We might call this *the problem of complexity of substance*. The brain is an example par excellence of a compositionally complex system. It has approximately 10^{10} neurons, each of which can have up to 10^4 connections with other neurons and 50 plus neurotransmitters (chemicals that are necessary for the neurons to work). Second, any principle of pattern formation must address not just how one pattern but many patterns are produced to accommodate different circumstances.

Biological structures like ourselves, for example, are multifunctional: we can use the same set of anatomical components for different behavioral functions as in eating and speaking, or different components to perform the same function (try writing your name with a pencil attached to your big toe). We might call this second problem *the problem of pattern complexity*. Moreover, how a given pattern persists under various environmental conditions (its *stability*) and how it adjusts to changing internal or external conditions (its *adaptability*) have to be accounted for. The processes that govern how a pattern is selected

from myriad possibilities must be incorporated in any set of organizational principles for living things. These processes often involve *cooperation* and *competition*, and a subtle interplay between the two.

Dynamic Instabilities

To explain the mechanisms underlying pattern formation, let's use the familiar example of a fluid heated from below and cooled from above. First, a word of caution. No one is saying that the brain (or living things in general) is simply a fluid composed of homogeneous elements. Far from it. Rather, the fluid as used here illustrates some of the ways nature handles complex nonequilibrium systems containing many degrees of freedom. In particular, it allows us to illustrate the key concepts of pattern formation and change that will provide a foundation for understanding the emergence of biological order and change. Like all great physical experiments, the beauty of the fluid example—called the Rayleigh-Bénard instability—is that even though it is performed in the laboratory, it opens the view to the bigger picture, such as weather patterns, cloud formation, and turbulence in fluids. This idea of choosing (some might say inventing) an experimental model system that adequately captures some of the essential features of the bigger (real world) problem will be a crucial theme throughout this book.

I often do a version of the Rayleigh-Bénard experiment with my daughter when I fry an egg for her on a Saturday morning. She gets a charge out of the patterns that form in the oil as it's heated. Here's how it goes (figure 1.1). Take a little cooking oil, put it in a pan, and heat it from below. If the temperature

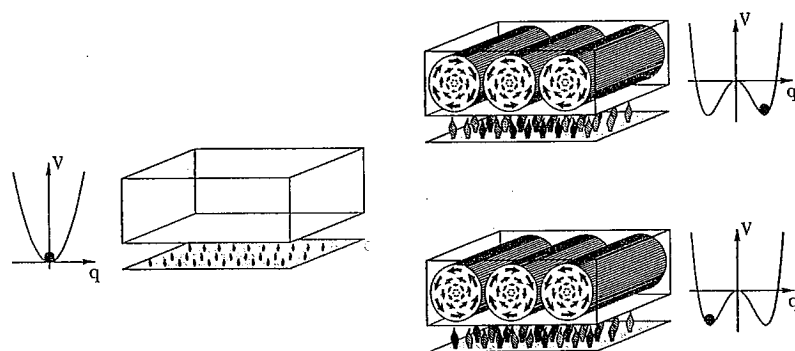

Figure 1.1 (Left). A layer of liquid heated weakly from below displays no macromotion. The liquid is in a rest state, as indicated by the ball resting in the minimum of the potential well. (Right). At a critical value of the temperature gradient the liquid displays macroscopic rolling motions. The ball can assume one of two possibilities, rolls rotating in one direction or the other.

difference between the top and bottom of the oil layer is small, there will be no large-scale motion of the liquid. Notice the liquid contains *very many molecules*, and the heat is dissipated among them as a random micromotion that we cannot see. We call this heat conduction.

Now already we see this is an *open system*, activated by the application of a temperature gradient that drives the motion. As this driving influence increases, an amazing event called an *instability* occurs. The liquid begins to move as a coordinated whole, no longer randomly but in an orderly, rolling motion. The reason for the onset of this motion is that the cooler liquid at the top of the oil layer is more dense and tends to fall, whereas the warmer and less dense oil at the bottom tends to rise. The resulting convection rolls are what physicists call a *collective* or *cooperative* effect, which arises without any external instructions. The temperature gradient is called a *control parameter* in the language of dynamical systems. Note that the control parameter does not prescribe or contain the code for the emerging pattern. It simply leads the system through the variety of possible patterns or states.

Rolling motions are not the only possibilities. In an open container, surface tension can also affect the flow. The net effect of this force is to minimize the surface area of the fluid, causing tessellation of the surface and the formation of hexagonal cells (figure 1.2 and plate 1). In the center of each hexagon, liquid rises, spreads out over the surface, and sinks at the perimeter where the

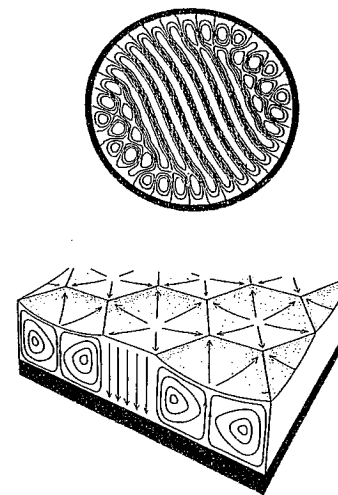

Figure 1.2 (Top) Convection rolls in the fluid as viewed from above. (Bottom) Tessellation of the liquid surface with hexagonal cells. Where the tension is greatest the surface becomes puckered, reducing surface area (Reprinted with permission from reference 13. Copyright © (1980) by Scientific American, Inc. All rights reserved.

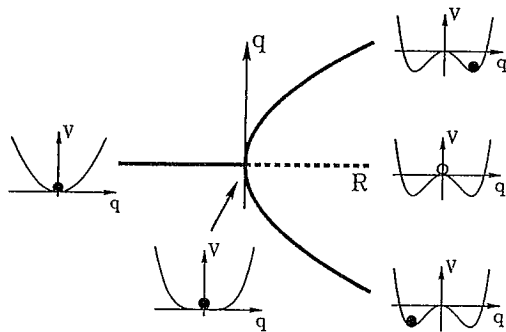

Figure 1.4 The corresponding bifurcation diagram and potential landscape V for the fluid behavior shown in figure 1.1. R is the control parameter and q represents the state of the fluid. Solid (open) balls represent stable (unstable) states of the potential. Similarly, thick lines are stable, dashed line is unstable.

Symmetry Breaking Fluctuations

A few more surprises are in store for us with this simple physical example. If we look at the arrangement of the convection rolls we see that their motion can be either in one direction or the other (see figure 1.1). Once this direction of motion begins in a particular cell, it will not change. But how does the fluid decide which way to go? The answer is Lady Luck herself. The symmetry of left- and right-handed motion is broken by an accidental fluctuation or perturbation. Of course, no agent-like entity inside the system decides which direction the fluid must go. Certainly, a decision appears to be made, but no decision maker tells the fluid what to do.

Bifurcations

Naturally, if one had a perfect system it would be equally probable that the rolls would go in one direction or the other. A good way to visualize this is the *bifurcation diagram* (figure 1.4). Below the critical control parameter value, R , for the onset of coherent motion, the only possible macroscopic state is the state of rest. The little ball representing the state of the fluid, q , is in the minimum of the potential, $V(q)$. At the instability point (shown by the arrow), a bifurcation (or branching) from this state of rest occurs: two rolling motions whose rotation speed is equal but opposite emerge spontaneously. Only one, of course, is realized in an experiment. Graphically, the little ball ends up in one well or the other. Notice the previously stable state (rest) is now unstable, shown by the dashed line in the bifurcation diagram and the open ball at the maximum of the potential.

This is a classic example of a *pitchfork bifurcation* (looks exactly as it sounds) between the state of rest and the state of macroscopic motion in one direction or the other. A stable solution of the dynamics becomes unstable, and a transition to bistability occurs. Bifurcations will be a persistent theme running throughout this book for a number of reasons. Here I'll just mention two. First, bifurcations constitute a mechanism for change and flexibility. Needless to say this isn't the smooth, inexorable gradual change advocated, for example, by Charles Darwin for the process of evolution. In self-organizing systems, a small change, say, in the temperature gradient applied to a fluid can produce a huge collective effect. Second, the bifurcation pictured in figure 1.4 nicely shows how open systems often have several options (here just two) for the same environmental conditions. Chance decides which solution nature adopts. Fluctuations are thus crucial to understanding how patterns are formed. They are always probing the stability of the system, allowing it to discover new and different ways to solve problems. Of course, fluctuations are intrinsic to all natural systems, not just a source of noise to be damped out. In certain cases that I'll describe later, they may actually help *amplify* weak background signals, a phenomenon that physicists and engineers refer to as stochastic resonance (see chapter 7).

Although our bifurcation picture only shows the first convection instability, more and more complex patterns—a whole hierarchy of instabilities—may arise if the temperature gradient is further increased. New patterns are created again and again in ever increasing complexity, until eventually the behavior becomes irregular and even turbulent. The components of the system (the fluid molecules) have almost too many options to adopt, and behavior never settles down. The analogies to society, the economy, and our mental health, although potentially misleading, are almost too powerful to overlook.

Origins of Instabilities: Competition versus Cooperation

The story is not quite over. A little more has to be said about the *origins* of instability. These are, I think, quite universal and will be important when we come to matters of the nervous system and behavior. As I said before, convective motion in the Bénard experiment is an example of a collective effect, which means cooperation among the many parts of the system. Lurking underneath this cooperativity, however, is competition. The competition, in this case, is between how forcefully we drive the system (buoyancy forces in the experiment are directly related to the temperature difference) and how well the system holds itself together (governed by two *dissipative forces*, viscosity and thermal conduction). The ratio of driving forces to dissipative forces is called the Rayleigh number (R in figure 1.4). It is dimensionless, since force quantities occupy the numerator and the denominator of the ratio, and these cancel, leaving just a number.

Subsequent instabilities depend on a second dimensionless number called the Prandtl number, which is the ratio of viscosity (the stickiness of the fluid

hexagons join. An important point is that two quite distinct mechanisms—one to do with buoyancy and the other surface tension—can give rise to the same dynamic pattern. Thus, the mechanism-pattern relation is not necessarily one to one. Similarly, the same mechanism can give rise to different patterns. This will turn out to be a dominant characteristic of biological systems as well, which we will have to explain.

Self-Organization

Such spontaneous pattern formation is exactly what we mean by *self-organization*: the system organizes itself, but there is no “self,” no agent inside the system doing the organizing. A single Bénard preparation might contain something on the order of 10^{20} molecules, each of which is subject to random disordered motion. But once the rolling motion starts, even in parts of the fluid, all these molecules begin to behave in a coherent fashion. The system is no longer merely a haphazard collection of randomly moving molecules: billions of molecules cooperate to create dynamic patterns synchronized in time, and extending over large distances in space many orders of magnitude larger than the molecular interaction. It's like a wave in Yankee stadium: the individual fans communicate and cluster together in groups to create a nearly synchronized pattern that spreads throughout the stadium.

In the Rayleigh-Bénard system the amplitude of the convection rolls plays the role of an *order parameter* or *collective variable*: all parts of the liquid no longer behave independently but are sucked into an ordered, coordinated pattern that can be described precisely using the order parameter concept. Where does this order parameter concept come from? It really comes out of what mathematicians call linear stability analysis (in our example, analysis of the equation of motion that describes the oil's behavior, which we won't go into here). The basic idea is that the initially random starting pattern can be considered as a superposition of a whole bunch of different vibratory modes described by this equation. For a given temperature gradient some (most) of these modes will be damped out. But others will increase in velocity, and the mode or pattern with the biggest rate of increase will dominate. This principle of the most unstable solution, called the *slaving principle* of synergetics,¹¹ serves as a *selection mechanism*: from random initial conditions a specific form of motion is favored. It's this coherent pattern that is described by the order parameter, and it is the order parameter dynamics that characterizes how patterns form and evolve in time. One of our main questions will be, what are the relevant collective variables and collective variable dynamics for complex systems such as the nervous system?

Collective Variables and Circular Causality

We should clarify one further important aspect of the collective variable or order parameter notion. In synergetics, the order parameter is created by the

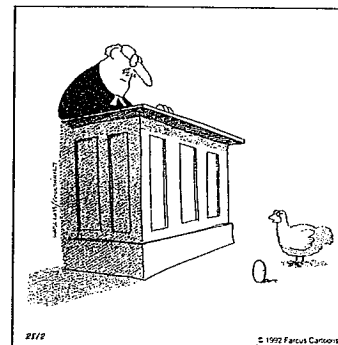

Excuse me your Honor, but I believe
I was here first.

Figure 1.3 The chicken and egg problem according to Farcus. (Reprinted with permission from Universal Press Syndicate)

cooperation of the individual parts of the system, here the fluid molecules. Conversely, it governs or constrains the behavior of the individual parts. This is a strange kind of *circular causality* (which is the chicken and which is the egg?), but we will see that it is typical of all self-organizing systems (figure 1.3). What we have here is one of the main conceptual differences between the circularly causal underpinnings of pattern formation in nonequilibrium systems and the linear causality that underlies most of modern physiology and psychology, with its inputs and outputs, stimuli and responses.

Some might argue that the concept of feedback closes the loop, as it were, between input and output. This works fine in simple systems that have only two parts to be joined, each of which affects the other. But add a few more parts interlaced together and very quickly it becomes impossible to treat the system in terms of feedback circuits. In such complex systems, as W. Ross Ashby elegantly pointed out years ago, the concept of feedback is inadequate.¹² What is more important is to realize that richly interconnected systems may exhibit both simple and complex behavioral patterns. Returning to the Bénard example, there is no reference state with which feedback can be compared and no place where comparison operations are performed. Indeed, *nonequilibrium steady states* emerge from the nonlinear interactions among the system's components, but there are no feedback-regulated set points or reference values as in a thermostat. Hence in the present case the questions of who sets the reference value, who programs the computer, who programs the programmer, and so on do not even arise. The child who breaks open a toy to find out how it works would be very disappointed if that toy was self-organized. Self-organizing systems have no *deus ex machina*, no ghost in the machine ordering the parts.

or the strength of intermolecular attraction) to thermal conductivity. But the message in each case is the same: once one force overcomes the other, instabilities arise, leading to rich and eventually irregular dynamic behaviors. Later on we will see in other kinds of systems, including the brain, that self-organization may arise due to competition not among conventional forces but among different sources of *information*. For now, the word "information" substitutes for the kinds of influences (external and internal) that affect the behavior of living things. An important point that will emerge is that information is *meaningful* and *specific* to the dynamic patterns that biological systems produce.

A further, somewhat related point has to be made before leaving our example and considering what this all means. Rayleigh and Prandtl numbers are dimensionless variables that deal with force fields. They tell us about how instabilities develop, and lead to pattern formation in physical and chemical systems. But it appears that we're left out something quite important. What role, if any, does the environment play? Now this has nothing to do with force in any conventional physical sense, but it does have to do with *geometry*.

In the Bénard example, the geometry takes the form of a third relevant dimensionless quantity called the *aspect ratio*, which relates a typical lateral (horizontal) dimension to the depth of the fluid. But unlike the temperature gradient that expresses the balance of forces and flows in an irreversible process, the aspect ratio is an environmental manipulation that measures the specific influence of lateral boundaries on convective patterns.¹³ Oil in a circular dish, for example, may give rise to the beautiful hexagonal honeycomb that is observed when the cell structure of the Bénard instability is viewed from above (plate 1). It's just this that excites my daughter on Saturday mornings when we fry an egg.

Turing Instabilities

Another class of dynamic pattern is analogous in many ways to the Bénard system, but based instead on *reaction-diffusion* processes. Reaction and diffusion turn out to be enormously important in chemical pattern formation, but the reason for discussing them here is that they may also play a role in *morphogenesis*, how biological pattern and form originates. Our friend Turing shows up again, because his pioneering paper "The chemical basis of morphogenesis," provided major insights into the problem. The story is told that when he was twelve years old, Turing entertained himself one summer by extracting iodine from seaweed. Some years later he won the science prize at his school for a mathematical analysis of an iodine clock reaction. Given this apparent preoccupation with iodine, it's fortuitous that Turing patterns were first unambiguously established in an *iodine reaction*, first by Patrick de Kepper's group in Bordeaux, France (1990), and shortly afterward by Harry Swinney's group in Austin, Texas.¹⁴

In his 1952 paper Turing showed that a spatially homogeneous distribution of chemicals (i.e., no pattern) could give rise by a so-called *Turing* (or diffusion-driven) *instability* to spatial patterns of different kinds.¹⁵ Turing suggested that this reaction-diffusion mechanism might explain such patterns as whorled leaves and the tentacle patterns on Hydra. But by far the most eye-catching application was (and is) the dappling patterns on the coats of animals such as the palomino horse, the giraffe, and the leopard.

How does the Turing instability work? Usually, diffusion is considered a stabilizing process rather than a source of destabilization. However, an analogy along the lines suggested by mathematical biologist James Murray, who has analyzed the Turing mechanism extensively, may help visualize the essential aspects of this novel idea.¹⁶ Consider a forest fire in which a flame front starts to propagate. The fire itself is a source of *activation*; the firefighters are pilots in helicopters spraying fire retardant, a source of *inhibition*. If the firefighters can spray the trees in advance of the flame front, the trees will be prevented from burning. If they cannot, then the fire will spread and the entire area will become charred. The intuitive idea is that the diffusion coefficient of the inhibitor must be much faster than the diffusion coefficient of the activator. That is to say, when the helicopter pilots see the flame front coming, they move ahead of it quickly, thus preventing the fire spreading into the area they've just sprayed. The charred area then is confined to a finite domain whose spatial pattern depends largely on the diffusion rates of activation (the fire) and inhibition (the firefighters). This basic description applies even if the fire begins in random places, rather than in a single location. Indeed, we can imagine the kind of dappling (spatial inhomogeneity) that would occur if the same scene were repeated around each locally distributed fire.

It turns out that one of the main mechanisms for realizing Turing patterns in the laboratory lies in this difference between the effective diffusion coefficients of the reactants. Istvan Lengyel and Irving Epstein showed that the inhibitor substance in the chemical reaction must move quickly relative to the activator.¹⁷ When it does, their model predicts exactly what was observed in experiments: a static pattern of dots containing high concentrations of iodine (plate 2). Almost every animal coat pattern, and probably the spots on tropical fishes, can be generated by this single diffusion-driven process. Instead of chemicals reacting in a gel, biological development is viewed as directed by the concentrations in cells of certain kinds of morphogens (hence morphogenesis). As in our analogy, the basic mechanism is generic: local activation (the fire) plus long-range inhibition (the firefighters).

Even though the mechanisms of reaction-diffusion and convection are different, the basic principles underlying pattern formation are the same. As a parameter governing the reaction is changed, one of the collective modes characterizing the pattern becomes unstable. All the others modes are stable. The principle of the least stable solution, Haken's slaving principle, runs the show again, and the process is entirely self-organized.¹⁸

Of course, many other factors are involved in biological development that we have not considered here, such as the geometry and scale of the embryonic cells themselves, and the timing of activation and inhibition. Murray provides an in-depth analysis of many of these factors, especially geometry and scale.¹⁹ So how, one might ask, does the gene, the unit of inheritance, fit into this picture? Speaking generally, one idea is that genes don't program biological development as if they contained a set of instructions for building an organism. If we calculated the information necessary to construct an organism, the figure is far larger than could ever be stored in DNA. Rather, it looks more as if the role of genes is to act as *specific* constraints on laws of self-organization. I realize this point is a bit vague at present, but the notion of *information as meaningful and specific to self-organized dynamical processes* will become a major part of the story later on (see especially, chapter 5). For now, I leave the reader with an anecdote attributed to Turing himself. When asked if his theory could explain the stripes on a zebra, he allegedly replied that the stripes were easy but the horse part was tricky.

Some Other Dynamic Patterns

Dynamic patterns, as I've emphasized, are not at all limited to inanimate matter. But for now, only a couple of examples. One that I find a little ironic concerns the molecular biologists' bread and butter, *Escherichia coli*, the common intestinal bacteria. A big splash was made in the *New York Times* science section (Sept. 1992) of the need for new principles to understand the fact that even single *E. coli* cells aggregate into tight balls to protect themselves when they are exposed to antibiotics or noxious stimuli. Lo and behold, they form all kinds of fantastic patterns that can't be predicted from the properties of single cells alone!

Dynamically patterned organization of unicellular organisms has actually been observed since the 1950s.²⁰ For example, one of the most extensively used models for cell patterning in development is the cellular slime mold *Dictyostelium discoideum*. When you remove the food supply of this little beast, the individual cells aggregate into a multicellular slug that can move about quite independently. When the slug stops moving, a fruiting body forms with densely packed spores. This eventually bursts apart, the amoebae are distributed, and the process begins all over again. Just as the molecules in the fluid interact with each other, so the single amoebae communicate by secreting an attractant whose concentration grows as more and more cells come into contact with it. Wave patterns form in a self-organized fashion entirely analogous to the Bénard instability.

A second example, perhaps closer to home, concerns how the visual cortex forms.²¹ This depends mostly on the spontaneous activity of the nervous system even without experience of visual stimuli. The big question is how organized regions in cortex, such as ocular dominance columns, can form based only on spontaneous neural activity. It turns out that an instability

mechanism, in the generic sense, also causes formation of ocular dominance patterns. From an initially random state in which all neurons in visual cortex receive roughly equal signals from the left and right eyes, symmetry is broken. Randomness is disrupted because neighboring cells are more likely to fire together. Like amoebae coupled by an attracting medium, when cells fire together, their connectivity is enhanced. Although initially each individual cortical neuron has an equal chance of connecting to the left or right eye, this balanced state is unstable. But all it takes is for one eye to be slightly more successful than the other in activating a single cortical neuron, and before you know it a preference for that eye is set up. Once again, the final dominance pattern is the one that dominates all the others that are mixed together to form the initially random state. The way you predict which ocular dominance column is going to form is to perturb the system a little bit, and observe at the moment of instability which pattern grows the fastest. This is the one that wins the "battle" between the two eyes.

Note again that the cortices of animals and people are not solely static structures, but are sculpted by dynamical processes. Dynamics gives meaning to geometrical forms while also being constrained by them. In short, the creation of structured forms such as ocular dominance columns in the cortex is *activity dependent*. As I said at the beginning of this chapter, the classic dichotomy between structure and function fades, and we begin to sense the intimate relation between them. Ultimately, all we are left with is dynamics, self-sustaining and persisting on several space-time scales, at all levels from the single cell up.

THE MESSAGES OF SELF-ORGANIZED PATTERNS

Nature is not economical of structures—only of principles.

—Abdus Salam

People and brains are not fluids or soap bubbles, as one well-known psychologist insisted after one of my lectures a few years ago. Brains obviously are highly interconnected entities, not continuous media. Life is not a bowl of cherries . . . or lime jello, for that matter. So what can we learn about people and brains from the classic example of the Bénard instability? Obviously, the point here is that it's the *organizational concepts* that matter, because they pertain to how complex structures or patterns can emerge and sustain themselves without any detailed instructions whatever. Such behavior is essential to the nature of things, and is not imposed from the outside. The Bénard example nicely illustrates the interplay between chance (fluctuations) and necessity (order) in effecting *selection* in a self-organized fashion. We will have other more pertinent examples later. Indeed, synergetic concepts shed an entirely new light on neo-Darwinism, which tends to ignore principles of self-organization in nonlinear dynamical systems.

We have seen how it is possible for structure and pattern to come "for free": under certain conditions the organization of matter undergoes abrupt change, almost without warning. Later on we will see that identifiable signatures or fingerprints can be detected in *advance* of upcoming change. For now, let's try to extract some of the main conceptual themes of pattern formation thus far, with the aim of using them to motivate our studies of brain and behavior. By summarizing the situation, my aim is to consolidate some of the key ideas that will turn up again and again throughout this book.

Elementary Concepts of and Conditions for Self-Organization

1. Patterns arise spontaneously as the result of large numbers of interacting components. If there aren't enough components or they are prevented from interacting, you won't see patterns emerge or evolve. The nature of the interactions must be nonlinear. This constitutes a major break with Sir Isaac Newton, who said in Definition II of the *Principia*: "The motion of the whole is the sum of the motion of all the parts." For us, the motion of the whole is not only greater than, but *different* than the sum of the motions of the parts, due to nonlinear interactions among the parts or between the parts and the environment.
2. The system must be *dissipative* and far from (thermal) equilibrium. Due to nonlinear interactions in the system, heat or energy doesn't diffuse uniformly but is concentrated into structural flows that transport the heat (dissipate it) more efficiently. As a result of dissipation, many of the system's degrees of freedom are suppressed and only a few contribute to the behavior. Intuitively, dissipation is equivalent to a kind of attraction that may take several forms (see 7 below).
3. *Relevant* degrees of freedom, those characterizing emerging patterns in complex systems, are called collective variables or order parameters in synergetics. An order parameter is created by the coordination between the parts, but in turn influences the behavior of the parts. This is what we mean by *circular causality*, which, incidentally, is not the same as tautology.
4. Order parameters are found near nonequilibrium phase transitions, where loss of stability gives rise to new or different patterns and/or switching between patterns. Order parameters may exist far from transitions as well, but it is difficult to identify them.
5. Fluctuations are continuously probing the system, allowing it to feel its stability and providing an opportunity to discover new patterns. Fluctuations are positive sources of noise, not just something to be rid of.
6. Parameters that lead the system through different patterns, but that (unlike order parameters) are not typically dependent on the patterns themselves, are called control parameters. Such control parameters may be quite *unspecific* in nature; that is, in no sense do they act as a code or a prescription for the emerging patterns. On the other hand, we will see that in biological systems

The Big Picture !

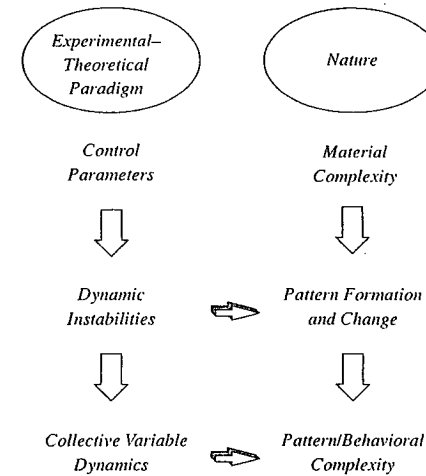

Figure 1.5 Summary of the big picture, from material complexity to behavioral complexity.

boundary conditions may be quite *specific* in an informational sense, especially when a particular pattern is required (cf. chapters 5 and 6).

7. The order parameter dynamics, the equation describing the coordinated motion of the system, may have simple (fixed point, limit cycle) or complicated solutions including deterministic chaos and stochastic (random) aspects thereby giving rise to enormous behavioral complexity.

Thus the main picture so far (summarized in figure 1.5) is that the complexity of matter or substance with all its microscopic constituents, gives rise through the dynamical mechanism of nonequilibrium phase transitions to simpler (lower-dimensional) order parameter dynamics that in turn are capable of generating enormous behavioral complexity. Nobel laureate Murray Gell-Mann is credited with saying, "Surface complexity arises out of deep simplicity." But actually we will see that the opposite is also true, namely, that *surface simplicity emerges out of deep complexity*.²² That message will ring out loud and clear when we consider in later chapters the experimental evidence in fields dealing, for example, with the coordinated behavior of people and brains.

The Tripartite Scheme

I want to say a little bit more about the generality (some might say universality) of the theoretical framework summarized here, and about the kinds of